

The Eliminator

Oil & Floating Debris Trap For Catch Basins

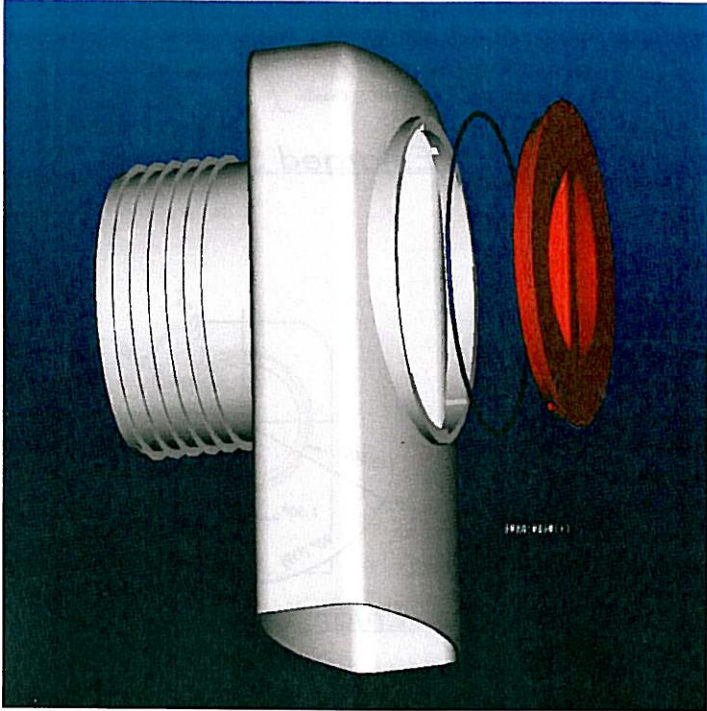

The ELIMINATOR Catch Basin Oil and Debris Trap is the most advanced trap of its kind on the market. Its clever design provides several unique features. Designed to follow the contours of round catch basins it offers the best clearance from the catch basin opening of any similar trap. Its unique neck design both seals and retains the trap in the outlet pipe. Manufactured from High Density Polyethylene it is lightweight, durable and resistant to the widest range of storm water contaminants. Its large inspection and maintenance port allows easy access to the outlet pipe with a quick quarter turn of the gasket sealed cover. Clearly the ELIMINATOR is the smart choice for your Catch Basins.

THE ELIMINATOR

- Eliminates oil and floating debris from the storm water waste stream.
- Eliminates prolonged exposure of workers to confined spaces as it installs in minutes.
- Eliminates waste as it is partially manufactured from recycled materials.
- Eliminates labor costs as it installs in minutes without fasteners, or adhesives.
- Eliminates maintenance problems as its low and contoured profile prevents dislodgment during catch basin cleaning.
- Eliminates confusion, it's the catch basin trap you will always want to use.



MANUFACTURED BY GROUND WATER RESCUE, INC.

24 Ryden Street, Quincy, MA 02169 * Tel: 617-773-1128 * Fax: 617-773-0510

www.kleanstream.com

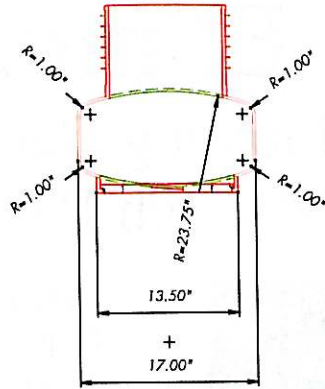
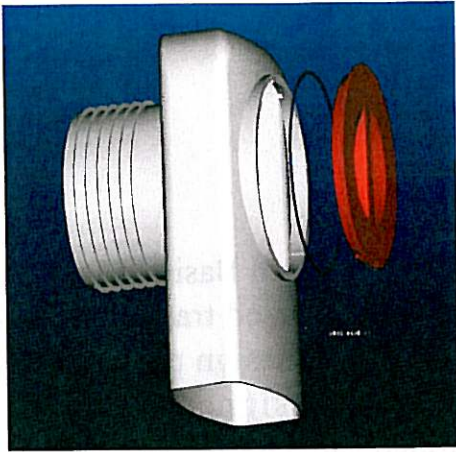

Enlarged Section 2-2

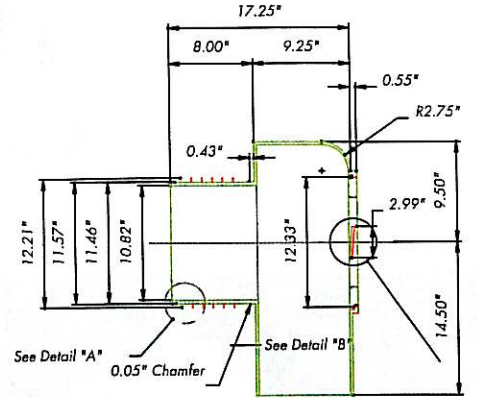

Enlarged Section 1-1

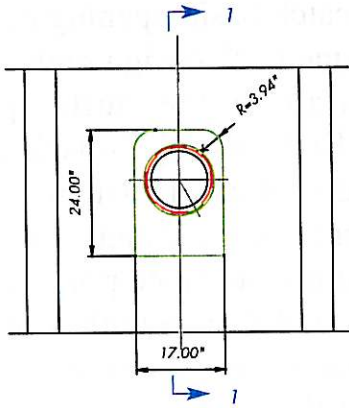

Front View

THE ELIMINATOR CATCH BASIN OIL & DEBRIS TRAP

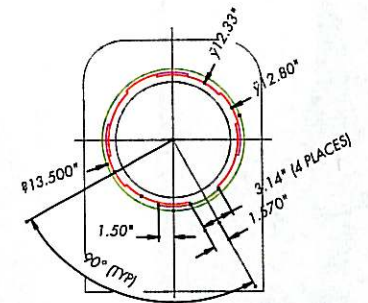

Enlarged Front View

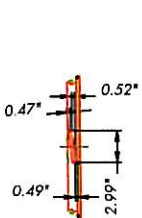

Side View of Cover

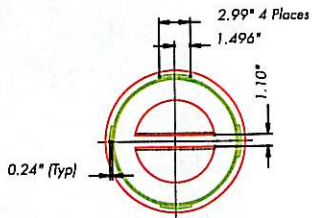

Rear View of Cover w/ Integral Handle

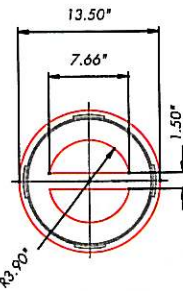

Front View of Cover w/ Integral Handle

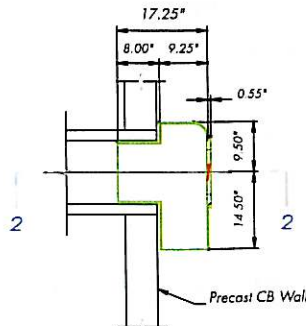
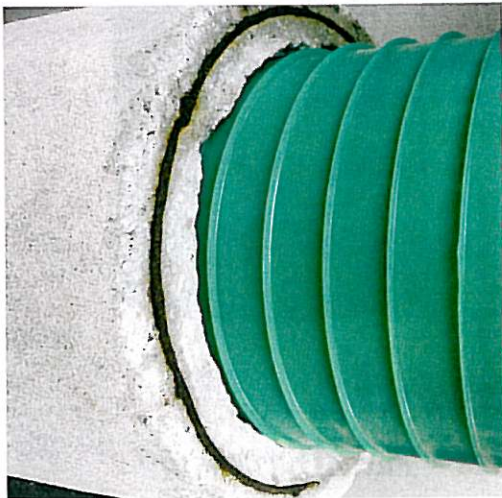

Section 1-1

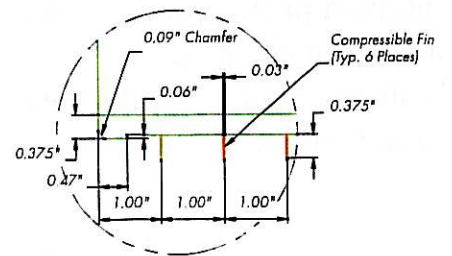

Detail "A"